

DESCRIPTION

The ModMAG[®] M1000 Electromagnetic Flow Meter is the result of years of research and field use of electromagnetic flow meter technology. Designed, developed and manufactured under strict quality standards, the M1000 features sophisticated, processor-based signal conversion with accuracies of ± 0.3 percent.

The M1000 can be chosen for a broad spectrum of applications and the wide selection of liner and electrode materials provide maximum compatibility and minimum maintenance over a long operating period.

OPERATION

The operating principle of the electromagnetic flow meter is based on Faraday's law of magnetic induction: The voltage induced across any conductor, as it moves at right angles through a magnetic field, is proportional to the velocity of that conductor. The voltage induced within the fluid is measured by two diametrically opposed internally mounted electrodes. The induced signal voltage is proportional to the product of the magnetic flux density, the distance between the electrodes and the average flow velocity of the fluid.

ELECTRODES

When looking from the end of the meter into the inside bore, the two measuring electrodes are positioned at three o'clock and nine o'clock. As a conductive fluid flows through the magnetic field, a voltage is induced across the electrodes. This voltage is proportional to the average flow velocity of the fluid and is measured by the two electrodes. This induced voltage is then amplified and processed digitally by the converter to produce an accurate analog or digital signal. The signal can then be used to indicate flow rate and totalization or to communicate to remote sensors and controllers.

The M1000 Electromagnetic Flow Meter also has an "empty pipe" detection feature. This is accomplished with a third electrode positioned in the meter between twelve o'clock and one o'clock. If this electrode is not covered by fluid for a minimum of five-seconds, the meter will display an "empty pipe" condition. When the electrode again becomes covered with fluid, the error message will disappear and the meter will continue measuring.

SENSOR

The flow meter is a stainless steel tube lined with a non-conductive material. Outside the tube, two DC powered electromagnetic coils are positioned opposing each other. Perpendicular to these coils, two electrodes are inserted into the flow tube. Energized coils create a magnetic field across the whole diameter of the pipe. With a no moving parts, open flow tube design there is no pressure lost and practically no maintenance required



APPLICATION

The M1000 Electromagnetic Flow Meter has been specifically designed for industrial water/wastewater, machinery plants, vehicles and batching process applications. Available in sizes 1/4...20 inch (DN 6...500) and nominal pressures up to 1450 psi (100 bar), the meter is best suited for bidirectional flow measurements of fluid $> 5 \mu\text{S}/\text{cm}$ ($> 20 \mu\text{S}/\text{cm}$ for demineralized water). The transmitter can be integrally mounted to the sensor, or if necessary, mounted remotely. The transmitter is housed in a Type NEMA 4X (IP67) enclosure and the measuring pipes are lined with material approved for drinking water: KTW/DVGW, NSF/ANSI/CAN 61 and 372, WRAS, ACS. Several process connections are available, including DIN flanges, dairy pipe connections and TriClamp[®].

FEATURES

- Accuracy $\pm 0.3\%$
- Flow range 0.03...12 m/s
- Sizes 1/4 ...20 in. (6...500 DN)
- LCD display
- Power supply 92...275V AC, 9...36V DC
- RS-232, RS-485 and RS-422 with Modbus[®] RTU
Optional Modbus TCP/IP, M-Bus or HART
- Integrated data logger

SPECIFICATIONS

NOTE: DN represents nominal diameter in mm.

Sensor Type II Specifications

The Sensor Type II is not only available in a number of different flange process connections (DIN, ANSI, JIS, AWWA) but also in a number of liners like hard rubber, soft rubber, PTFE, PFA or Halar. Available in sizes 1/4...20 inch (DN 6...500) and nominal pressures up to 1450 psi (100 bar), the Sensor Type II is best suited for a variety of applications in the industry and the water/waste water industry. Lined measuring pipes with materials approved for drinking water: KTW/DVGW, NSF/ANSI/CAN 61 and 372, WRAS, ACS.

Size	1/4...20 in. (DN 6...500)		
Process Connections	Flange: DIN, ANSI, JIS, AWWA		
Nominal Pressure	Up to 1450 psi (100 bar) (PED)		
Protection Class	IP 67, IP 68 optional		
Minimum Conductivity	5 µS/cm (20 µS/cm demineralized water)		
Liners	Hard/soft rubber	1 in. (DN 25) and up	32...176° F (0...80° C)
	PFA	1/4...3/8 in. (DN 6...10)	-40...302° F (-40...150° C)
	PTFE	1/2...20 in. (DN 15...500)	-40...302° F (-40...150° C)
Electrodes	Hastelloy C (Standard)	Platinum/Gold platinized	
	Tantalum	Platinum/Rhodium	
Body	Steel/stainless steel optional		
Grounding Rings	Stainless steel		

Process Connection Flange Remote Version in. (mm)

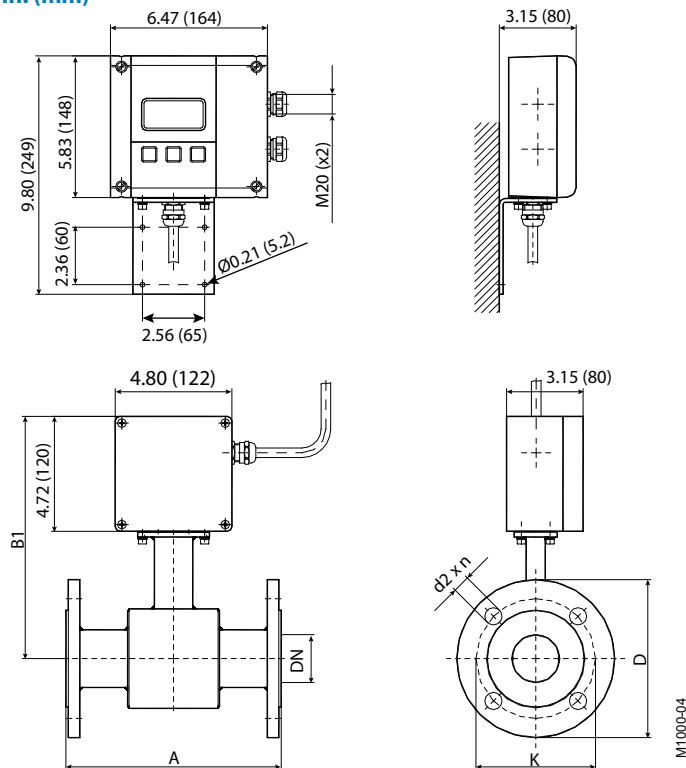

Process Connection Flange Mounted Version in. (mm)

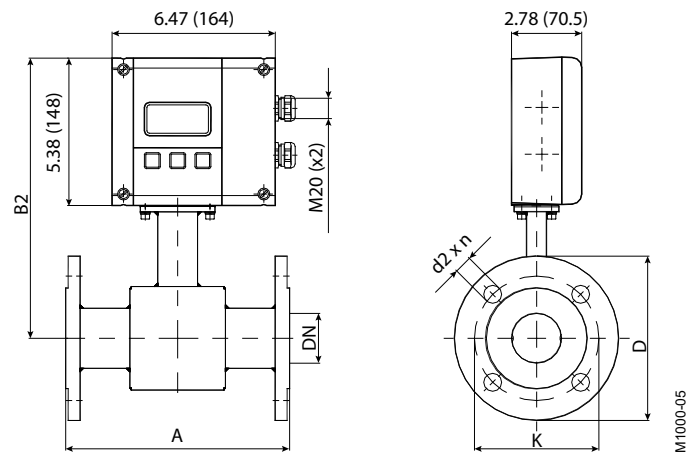

Size		A Std* in. (mm)	A ISO** in. (mm)	B1 in. (mm)	B2 in. (mm)	ANSI Flanges			DIN Flanges			Finish Est. Wt. lb (kg)
Inches	DN					D in. (mm)	K in. (mm)	d2xn in. (mm)	D in. (mm)	K in. (mm)	d2xn in. (mm)	
1/4 in.	6	6.69 (170)	—	8.98 (228)	10.08 (256)	3.50 (88.9)	2.37 (60.3)	0.63 × 4 (15.9 × 4)	3.54 (90)	2.37 (60)	0.55 × 4 (14 × 4)	9.04 (4.1)
5/16 in.	8	6.69 (170)	—	8.98 (228)	10.08 (256)	3.50 (88.9)	2.37 (60.3)	0.63 × 4 (15.9 × 4)	3.54 (90)	2.37 (60)	0.55 × 4 (14 × 4)	9.04 (4.1)
3/8 in.	10	6.69 (170)	—	8.98 (228)	10.08 (256)	3.50 (88.9)	2.37 (60.3)	0.63 × 4 (15.9 × 4)	3.54 (90)	2.37 (60)	0.55 × 4 (14 × 4)	9.04 (4.1)
1/2 in.	15	6.69 (170)	7.87 (200)	9.37 (238)	10.47 (266)	3.50 (88.9)	2.37 (60.3)	0.63 × 4 (15.9 × 4)	3.74 (95)	2.56 (65)	0.55 × 4 (14 × 4)	9.04 (4.1)
3/4 in.	20	6.69 (170)	7.87 (200)	9.37 (238)	10.47 (266)	3.87 (98.4)	2.75 (69.8)	0.63 × 4 (15.9 × 4)	4.13 (105)	2.95 (75)	0.55 × 4 (14 × 4)	11.24 (5.1)
1 in.	25	8.86 (225)	7.87 (200)	9.37 (238)	10.47 (266)	4.25 (107.9)	3.13 (79.4)	0.63 × 4 (15.9 × 4)	4.53 (115)	3.35 (85)	0.55 × 4 (14 × 4)	16.76 (7.6)
1-1/4 in.	32	8.86 (225)	7.87 (200)	9.96 (253)	11.06 (281)	4.63 (117.5)	3.50 (88.9)	0.63 × 4 (15.9 × 4)	5.51 (140)	3.94 (100)	0.71 × 4 (18 × 4)	18.96 (8.6)
1-1/2 in.	40	8.86 (225)	7.87 (200)	9.96 (253)	11.06 (281)	5.00 (127)	3.87 (98.4)	0.63 × 4 (15.9 × 4)	5.91 (150)	4.33 (110)	0.71 × 4 (18 × 4)	20.06 (9.1)
2 in.	50	8.86 (225)	7.87 (200)	9.96 (253)	11.06 (281)	6.00 (152.4)	4.75 (120.6)	0.75 × 4 (19 × 4)	6.50 (165)	4.92 (125)	0.71 × 4 (18 × 4)	24.47 (11.1)
2-1/2 in.	65	11.02 (280)	7.87 (200)	10.67 (271)	11.77 (299)	7.00 (177.8)	5.5 (139.7)	0.75 × 4 (19 × 4)	7.28 (185)	5.71 (145)	0.71 × 8 (18 × 8)	50.92 (23.1)
3 in.	80	11.02 (280)	7.87 (200)	10.67 (271)	11.77 (299)	7.50 (190.5)	6.00 (152.4)	0.75 × 4 (19 × 4)	7.87 (200)	6.30 (160)	0.71 × 8 (18 × 8)	53.13 (24.1)
4 in.	100	11.02 (280)	9.84 (250)	10.94 (278)	12.05 (306)	9.00 (228.6)	7.50 (190.5)	0.75 × 8 (19 × 8)	8.66 (220)	7.09 (180)	0.71 × 8 (18 × 8)	55.34 (25.1)
5 in.	125	15.75 (400)	9.84 (250)	11.73 (298)	12.83 (326)	10.00 (254)	8.50 (215.9)	0.85 × 8 (22.2 × 8)	9.84 (250)	8.27 (210)	0.71 × 8 (18 × 8)	56.44 (25.6)
6 in.	150	15.75 (400)	11.81 (300)	12.20 (310)	13.31 (338)	11.00 (279.4)	9.50 (241.3)	0.85 × 8 (22.2 × 8)	11.22 (285)	9.45 (240)	0.87 × 8 (22 × 8)	58.64 (26.6)
8 in.	200	15.75 (400)	13.78 (350)	13.31 (338)	14.41 (366)	13.5 (342.9)	11.75 (298.4)	0.85 × 8 (22.2 × 8)	13.39 (340)	11.61 (295)	0.87 × 12 (22 × 12)	85.10 (38.6)
10 in.	250	19.69 (500)	17.72 (450)	14.25 (362)	15.35 (390)	16.00 (406.4)	14.25 (361.9)	1.00 × 12 (25.4 × 12)	15.55 (395)	13.78 (350)	0.87 × 12 (22 × 12)	—
12 in.	300	19.69 (500)	19.69 (500)	16.73 (425)	17.83 (453)	19.00 (482.6)	17.00 (431.8)	1.00 × 12 (25.4 × 12)	17.52 (445)	15.75 (400)	0.87 × 12 (22 × 12)	—
14 in.	350	19.69 (500)	21.65 (550)	17.72 (450)	18.82 (478)	21.00 (533.4)	18.75 (476.2)	1.13 × 12 (28.6 × 12)	19.88 (505)	18.11 (460)	0.87 × 16 (22 × 16)	—
16 in.	400	23.62 (600)	23.62 (600)	18.70 (475)	19.80 (503)	23.5 (596.9)	21.25 (539.7)	1.13 × 16 (28.6 × 16)	22.24 (565)	20.28 (515)	1.02 × 16 (26 × 16)	—
18 in.	450	23.62 (600)	—	19.69 (500)	20.79 (528)	25.00 (635.0)	22.75 (577.8)	1.25 × 16 (31.7 × 16)	24.21 (615)	22.24 (565)	1.02 × 20 (26 × 20)	—
20 in.	500	23.62 (600)	—	20.67 (525)	21.42 (554)	27.50 (698.5)	25.00 (635.0)	1.25 × 20 (31.7 × 20)	26.38 (670)	24.41 (620)	1.02 × 20 (26 × 20)	—
Standard												
ANSI flanges		1/4...20 in. Class 150				Nominal Pressure 284 psi (19.6 bar) at 68° F (20° C) for C-Steel flanges						
DIN flanges		1/4...8 in. (DN 6...200)				Nominal Pressure 232 psi (16 bar)						
		10...20 in. (DN 250...500)				Nominal Pressure 145 psi (10 bar)						
* Standard												
**ISO 20456												

Sensor with Sanitary Process Connections Specifications

The sensor model is available with Tri-Clamp, DIN 11851, ISO2852 or BS4825 process connections. The sanitary sensor is delivered in a stainless steel housing and with PTFE lining.

Size	3/8...4 in. (DN 10...100)		
Process Connections	Tri-Clamp®, DIN 11851, ISO2852, BS4825 and customer specified.		
Nominal Pressure	Tri-Clamp connection	145 psi (10 bar)	
	DIN 11851 connection	230 psi (16 bar)	
Protection Class	IP 67, IP 68 optional		
Minimum Conductivity	5 µS/cm(20 µS/cm demineralized water)		
Liners	PTFE	-40...302° F (-40...150° C)	
Electrodes	Hastelloy C (Standard)	Platinum/Gold Platinized	
	Tantalum	Platinum/Rhodium	
Body	Stainless steel		
Overall Length	Tri-Clamp connection	3/8...2 in. (DN 10...50)	5.71 in. (145 mm)
		2-1/2...4 in. (DN 65...100)	7.87 in. (200 mm)
	DIN 11851 connection	3/8...3/4 in. (DN 10...20)	6.69 in. (170 mm)
		1...2 in. (DN 25...50)	8.86 in. (225 mm)
		2-1/2...4 in. (DN 65...100)	11.02 in. (280 mm)

Tri-Clamp Connection Remote Version
in. (mm)

DIN 11851 Connection Remote Version
in. (mm)

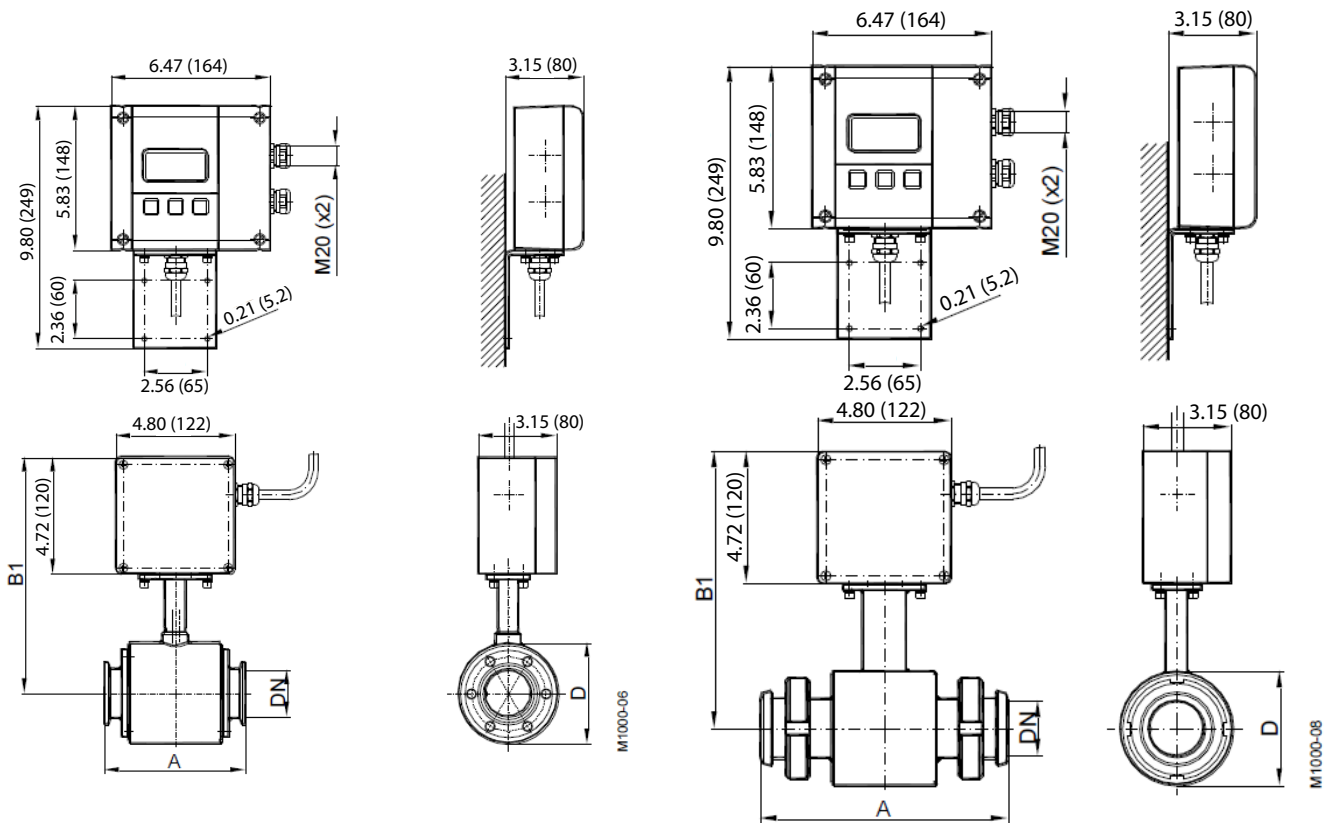

Tri-Clamp Connection Mounted Version
in. (mm)

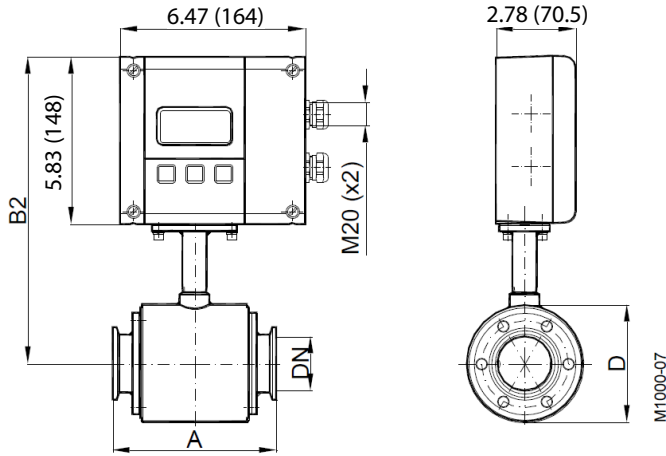

DIN 11851 Connection Mounted Version
in. (mm)

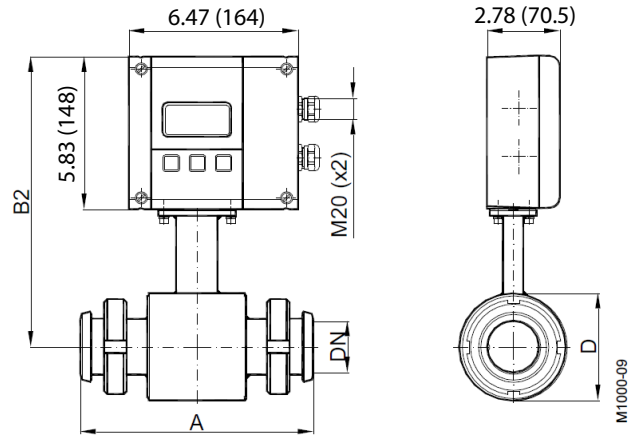

Tri-Clamp					
Size		A	B1	B2	D
Inches	DN	in. (mm)	in. (mm)	in. (mm)	in. (mm)
3/8 in.	10	5.71 (145)	8.98 (228)	10.08 (256)	2.91 (74)
1/2 in.	15	5.71 (145)	8.98 (228)	10.08 (256)	2.91 (74)
3/4 in.	20	5.71 (145)	8.98 (228)	10.08 (256)	2.91 (74)
1 in.	25	5.71 (145)	8.98 (228)	10.08 (256)	2.91 (74)
1-1/2 in.	40	5.71 (145)	9.37 (238)	10.47 (266)	3.70 (94)
2 in.	50	5.71 (145)	9.57 (243)	10.67 (271)	4.09 (104)
2-1/2 in.	65	7.87 (200)	10.08 (256)	11.18 (284)	5.08 (129)
3 in.	80	7.87 (200)	10.28 (261)	11.38 (289)	5.51 (140)
4 in.	100	7.87 (200)	10.59 (269)	11.69 (297)	6.14 (156)
Nominal Pressure 145 psi (10 bar)					

DIN 11851					
Size		A	B1	B2	D
Inches	DN	in. (mm)	in. (mm)	in. (mm)	in. (mm)
3/8 in.	10	6.69 (170)	9.37 (238)	10.47 (266)	2.91 (74)
1/2 in.	15	6.69 (170)	9.37 (238)	10.47 (266)	2.91 (74)
3/4 in.	20	6.69 (170)	9.37 (238)	10.47 (266)	2.91 (74)
1 in.	25	8.86 (225)	9.37 (238)	10.47 (266)	2.91 (74)
1-1/4 in.	32	8.86 (225)	9.57 (243)	10.67 (271)	3.31 (84)
1-1/2 in.	40	8.86 (225)	9.76 (248)	10.87 (276)	3.70 (94)
2 in.	50	8.86 (225)	9.96 (253)	11.06 (281)	4.09 (104)
2-1/2 in.	65	11.02 (280)	10.47 (266)	11.57 (294)	5.08 (129)
3 in.	80	11.02 (280)	10.67 (271)	11.77 (299)	5.51 (140)
4 in.	100	11.02 (280)	10.98 (279)	12.09 (307)	6.14 (156)
Nominal Pressure 232 psi (16 bar)					

Tri-Clamp Connection Standards BS4825/ISO2852

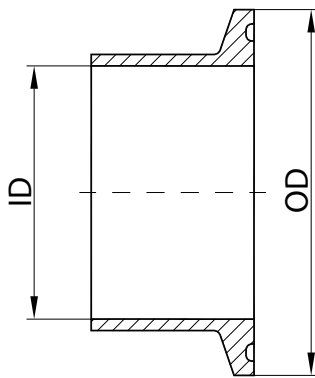

BS4825					ISO2852				
Size	OD		ID		Size	OD		ID	
in.	in.	mm	in.	mm	DN	in.	mm	in.	mm
—	—	—	—	—	10	0.98	25.0	0.55	14.0
1/2	0.98	25.0	0.37	9.4	15	1.99	50.5	0.71	18.1
3/4	0.98	25.0	0.62	15.75	20	1.99	50.5	0.90	22.9
1	1.99	50.5	0.87	22.1	25	1.99	50.5	1.13	28.7
—	—	—	—	—	32	2.52	64.0	1.51	38.4
1-1/2	1.99	50.5	1.37	34.8	40	2.52	64.0	1.74	44.3
2	2.52	64.0	1.87	47.5	50	3.05	77.5	2.22	56.3
2-1/2	3.05	77.5	2.37	60.2	65	3.58	91.0	2.84	72.1
3	3.58	91.0	2.87	72.9	80	4.17	106.0	3.32	84.3
4	4.69	119.0	3.83	97.4	100	5.12	130.0	4.32	109.7
Nominal Pressure 145 psi (10 bar)									

Sensor Type III Specifications

Thanks to its very short lay length, the Sensor Type III is often the right alternative. Delivered with a PTFE liner, the Sensor Type III has a standard nominal pressure of 580 psi (40 bar).

Size	1...4 in. (DN 25...100)	
Process Connections	Wafer connection, (intermediate flange mounting)	
Nominal Pressure	580 psi (40 bar)	
Protective Class	IP 67, IP 68 optional	
Minimum Conductivity	5 µS/cm(20 µS/cm demineralized water)	
Liner	PTFE	-40...302° F (-40...150° C)
Electrodes	Hastelloy C (Standard) Tantalum	Platinum/Gold platinized Platinum/Rhodium
Body	Steel/stainless steel optional	
Grounding Rings	Stainless steel	
Overall Length	1...2 in. (DN 25...50)	3.94 in. (100 mm)
	2-1/2...4 in. (DN 65...100)	5.91 in. (150 mm)

Process Connection Wafer Remote Version in. (mm)

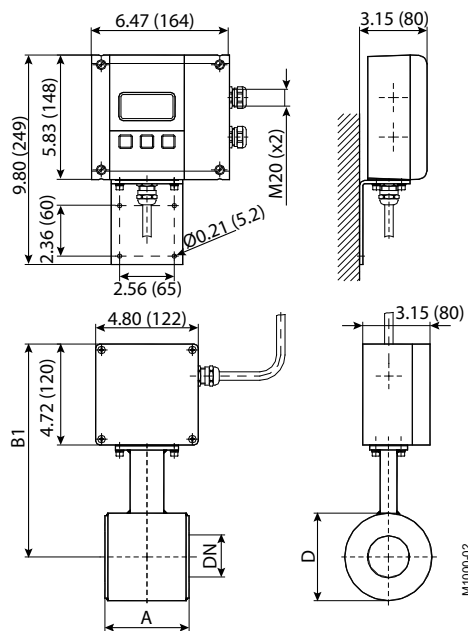

Process Connection Wafer Mounted Version in. (mm)

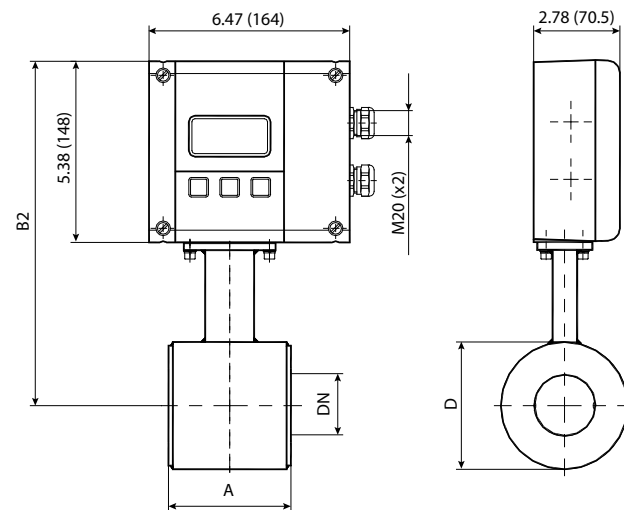

M1000-03

Size		A in. (mm)	B1 in. (mm)	B2 in. (mm)	D in. (mm)
Inches	DN				
1 in.	25	3.94 (100)	9.37 (238)	10.47 (266)	2.91 (74)
1-1/4 in.	32	3.94 (100)	9.57 (243)	10.67 (271)	3.31 (84)
1-1/2 in.	40	3.94 (100)	9.76 (248)	10.87 (276)	3.70 (94)
2 in.	50	3.94 (100)	9.96 (253)	11.06 (281)	4.09 (104)
2-1/2 in.	65	5.91 (150)	10.47 (266)	11.57 (294)	5.08 (129)
3 in.	80	5.91 (150)	10.67 (271)	11.77 (299)	5.51 (140)
4 in.	100	5.91 (150)	10.98 (279)	12.09 (307)	6.14 (156)

Nominal Pressure 580 psi (40 bar)

Transmitter Type ModMAG M1000 Specifications

Type	ModMAG M1000
Auxiliary Power	92...275V AC (50 / 60 Hz), 13VA optional 9...36V DC, 4 W
Analog Output	0/4...20 mA, $\leq 800 \text{ Ohm}$ / 0...10 mA Flow direction is displayed via separate status output
Digital Outputs	2 open collectors, passive 32V DC, 0...100 Hz 100 mA, 100...10,000 Hz 20 mA, optional active Pulse, status, error messages
Digital Inputs	Totalizers and preselectors reset Positive Zero Return
Frequency Output	10 kHz
Empty Pipe Detection	Separate electrode for empty pipe detection / field-tunable for optimal performance
Configuration	3 external buttons
Interfaces	RS232, RS422, RS485, ModBus RTU, Optional ModBus TCP/IP, M-Bus or HART
Measuring Range	0.10...39.37 ft/s (0.03...12 m/s)
Measuring Accuracy	0.3% of reading $\pm 0.08 \text{ in./s}$ (2 mm/s)
Reproducibility	0.1%
Flow Direction	Uni-directional and bi-directional
Pulse Length	Configurable up to 2000 msec
Outputs	Short-circuit-proof and galvanically separated
Low Flow Cutoff	0...10%
Display	Graphical LCD 64 \times 128, backlight, actual flow rate, totalizers, status display
Housing	Powder-coated aluminum die casting
Mounting	Sensor or remote wall mount
Protective Class	IP 67
Cable Insert	Supply and signal cables 2 \times M20
Remote Signal Cable	Up to 164 ft / 50 m
Coil Power	Pulsed DC
Altitude	8202 ft (2500 m)
Ambient Temperature	-4...140° F (-20...60° C)
Humidity	90% R.H. max
Approvals	NSF/ANSI/CAN 61 and 372 Listed: Models with hard rubber liner 4 in. size and up; PTFE liner, all sizes
Pollution Degree	2
Installation Category	II
Units of Measure	Gallons, ounces, MGD, liters, cubic meters, cubic feet, imperial gallon, barrel, hectoliter and acre-feet

ModMAG M1000 Transmitter in. (mm)

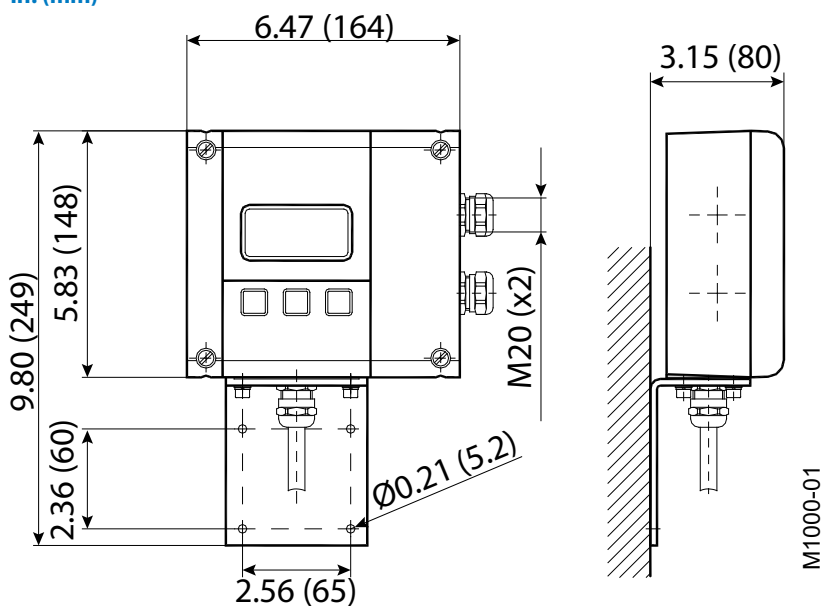

SIZE SELECTION

Size		Flow Range	
Inches	DN	US	Metric
1/4	6	0.0134...5.4 GPM	0.051...20.4 l/min
3/10	8	0.0239...9.6 GPM	0.090...36.2 l/min
3/8	10	0.0373...14.9 GPM	0.141...57 l/min
1/2	15	0.084...33.6 GPM	0.318...127 l/min
3/4	20	0.149...60 GPM	0.57...226 l/min
1	25	0.233...93 GPM	0.88...353 l/min
1 1/4	32	0.382...153 GPM	1.45...579 l/min
1 1/2	40	0.60...239 GPM	2.26...905 l/min
2	50	0.93...373 GPM	3.53...1414 l/min
2 1/2	65	1.58...631 GPM	0.358...143 m ³ /h
3	80	2.39...956 GPM	0.54...217 m ³ /h
4	100	3.73...1494 GPM	0.85...339 m ³ /h
5	125	5.8...2334 GPM	1.33...530 m ³ /h
6	150	8.4...3361 GPM	1.91...763 m ³ /h
8	200	14.9...5975 GPM	3.39...1357 m ³ /h
10	250	23.3...9336 GPM	5.3...2121 m ³ /h
12	300	33.6...13,444 GPM	7.6...3054 m ³ /h
14	350	45.7...18,299 GPM	10.4...4156 m ³ /h
16	400	60...23,901 GPM	13.6...5429 m ³ /h
18	450	76...30,250 GPM	17.2...6870 m ³ /h
20	500	93...37,345 GPM	21.2...8482 m ³ /h

PART NUMBER CONSTRUCTION

If you are interested in a product configuration that is not designated for your region, please contact Badger Meter.

Sensor and Transmitter Ordering Information for North America

M1	Meter Type	Detector			Electrodes & Grounding	Amplifier	Remote Cable Length	Communications/Outputs	Wiring Method	Unit of Measure Totalizer/Flow Rate	Testing & Tagging
		HARD RUBBER C-Steel 150# flanges R1	PTFE C-Steel 150# flanges P1	PFA Stainless Steel 150# flanges PA							
M1000	Meter Type- Standard LL										
	1/4 in.	002	N/A	N/A	—						
	5/16 in.	003	N/A	N/A	—						
	3/8 in.	004	N/A	N/A	—						
	1/2 in.	005	N/A	—	N/A						
	3/4 in.	007	N/A	—	N/A						
	1 in.	010	—	—	N/A						
	1-1/4 in.	012	—	—	N/A						
	1-1/2 in.	015	—	—	N/A						
	2 in.	020	—	—	N/A						
	2-1/2 in.	025	—	—	N/A						
	3 in.	030	—	—	N/A						
	4 in.	040	—	—	N/A						
	5 in.	050	—	—	N/A						
	6 in.	060	—	—	N/A						
	8 in.	080	—	—	N/A						
	10 in.	100	—	—	N/A						
	Electrodes and Grounding										
	Alloy C with 316 Stainless Steel Grounding Rings				A						
	Amplifier Type										
	110/220V AC; Meter Mounted					M					
	110/220V AC; Remote Mounted					R					
	110/220V AC; Remote Mounted; Submersible					S					
	24V DC; Meter Mounted					E					
	24V DC; Remote Mounted					F					
	24V DC; Remote Mounted; Submersible					G					
	Remote Cable Length										
	None						WW				
	5 ft.; Standard Cable						AA				
	10 ft.; Standard Cable						AB				
	15 ft.; Standard Cable						AC				
	30 ft.; Standard Cable						AF				
	50 ft.; Standard Cable						AK				
	75 ft.; Standard Cable						AR				
	100 ft.; Standard Cable						BW				
	125 ft.; Standard Cable						BE				
	150 ft.; Standard Cable						BK				
	Communications/Outputs										
	Standard Output							S			
	Standard Output with Modbus TCP/IP							T			
	Wiring Method										
	None								XX		
	Twist Tight - 5 ft. (MTR, ASSY)								TF		
	Twist Tight - 10 ft. (MTR, ASSY)								TH		
	Twist Tight - 25 ft. (MTR, ASSY)								TJ		
	Twist Tight - 75 ft. (MTR, ASSY)								TK		
	Nicor - 6 ft. (MTR, ASSY)								NG		
	Nicor - 25 ft. (MTR, ASSY)								NJ		
	Itron - 5 ft. (MTR, ASSY)								CF		
	Itron - 25 ft. (MTR, ASSY)								CJ		
	Unit of Measure Totalizer/ Flow Rate										
	Gallons/gallons per minute									G	
	Gallons/cubic feet per minute									B	
	Gallons/cubic meters per second									D	
	Cubic Meters/gallons per minute									C	
	Cubic Meters/cubic meters per second									E	
	Cubic Meters/cubic meters per minute									T	
	Cubic Meters/cubic meters per hour									H	
	Cubic Feet/gallons per minute									F	
	Cubic Feet/cubic feet per minute									J	
	Cubic Feet/cubic meters per hour									K	
	Liters/gallons per minute									L	
	Liters/liters per second									N	
	Liters/liters per minute									P	
	Liters/liters per hour									Q	
	Million Gallons/gallons per minute									M	
	Gallons/millions gallons per day									R	
	Acre Feet/gallons per minute									A	
	Second-Foot Day/cubic feet per second									S	
	Custom Units									Z	
	Testing and Tagging										
	Factory Calibrated										F
	3rd Party Calibrated										3
	Factory Calibrated/Stainless Steel Tag										S
	3rd Party Calibrated w/ Stainless Steel Tag										T
	State of Kansas Certified										K

Sensor Ordering Information for International

	MID	-	/	-	/	-	-	/	-	-
Model										
MID electromagnetic flow meter	MID									
Type										
Type 2	2									
Type 3	3									
Type 5	5									
Type 6	6									
Size										
DN 6 to DN 2000										
Pressure rate										
Process connection										
DIN flanges						F				
ANSI flanges						A				
Threads acc. DIN 11851						D				
Tri-Clamp®						T				
Wafer						W				
Material										
C-steel						ST				
SST 1.4301 (ANSI 304)						V2				
SST 1.4404 (ANSI 316)						V4				
Liner										
PTFE								PT		
(DN 6-10)								PFA		
Hard rubber								HG		
Softrubber								WG		
Halar								HA		
Electrodes										
Measure + empty pipe electrode									ML	
Measure + grounding + empty pipe electrode									MEL	
Electrode material										
Hastelloy C									HC	
Tantalum									TA	
Platinum/gold plated									PG	
Platinum/Rhodium									PR	
Housing										
C-steel										St
SST 1.4301 (ANSI 304)										V2
SST 1.4404 (ANSI 306)										V4

Transmitter Ordering Information for International

					m
M1000 (92...275V AC)	M10A				
M1000 (9...36V DC)	M10D				
M1000 blind version (V AC)	MB10A				
M1000 blind version (V DC)	MB10D				
M1000 blind version, with stainless steel housing (V AC)	MBS10A				
M1000 blind version, with stainless steel housing (V DC)	MBS10D				
Mounted/remote/cable length					
Amplifier detector mounted			M		
Remote version cable length			R		
Remote amplifier with cable length					
Remote amplifier with 10 m cable length					10
Remote amplifier with 15 m cable length					15
Remote amplifier with 20 m cable length					20
Remote amplifier with 25 m cable length					25
Remote amplifier with 30 m cable length					30

INTENTIONAL BLANK PAGE

Control. Manage. Optimize.

ModMAG is a registered trademark of Badger Meter, Inc. Other trademarks appearing in this document are the property of their respective entities. Due to continuous research, product improvements and enhancements, Badger Meter reserves the right to change product or system specifications without notice, except to the extent an outstanding contractual obligation exists. © 2021 Badger Meter, Inc. All rights reserved.

www.badgermeter.com